

1 2 3 4

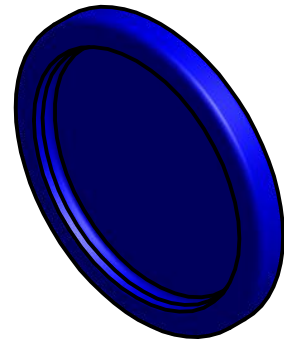

A
B
C
D
E

Z (20 : 1)

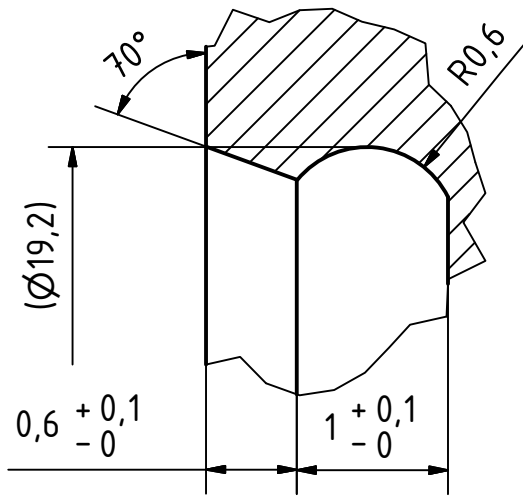

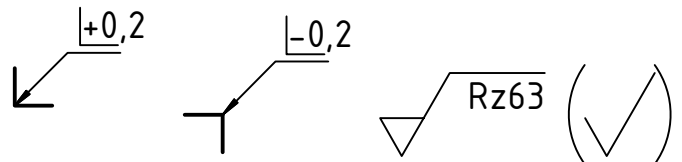
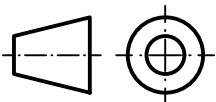
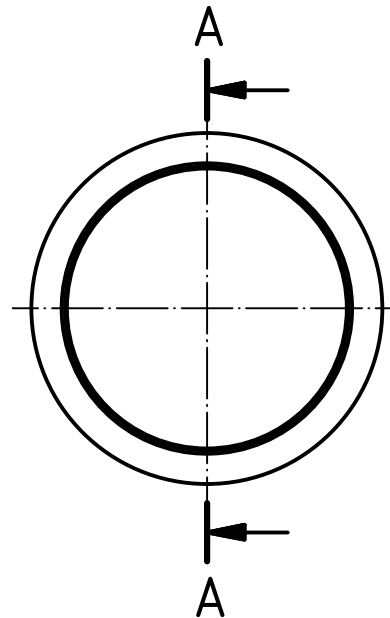
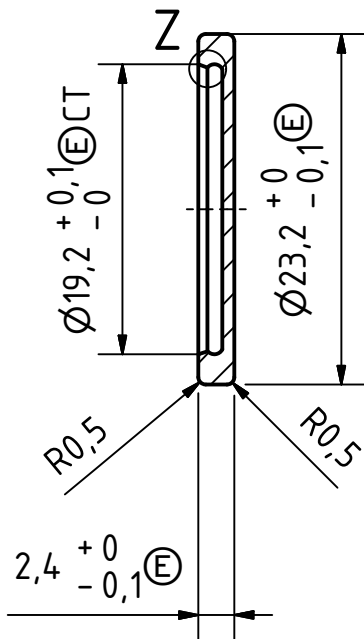
A-A



| | | | | |
|---|----------------------------------|---|-------------------------------|----------------------|
| Scale 2:1 | General Tolerance ISO 2768-cL | Surface ISO 1302 | Material PLA | Raw Part 3D Print |
| Tolerance ISO 8015 | Length Tolerance ISO 14405-1 | Angle Tolerance ISO 14405-3 | Document Type Part Drawing | |
|   | Done by Marcus Goppelmann | Name, additional Name Chip - Bottom Part | | Number BKT-DN-001 |
| | Approved by Axel Grossmann | Rev. | Date 04.04.2017 | Size A4 |
| | | | | Sheet 1/1 |